

BOM LIST			
ITEM	PART NAME	Q'ty	NOTES
1	PLASTIC HOOD	2	ABS
2	2.1 LONG BOLT	2	#4-40
	2.2 SHORT BOLT	2	#4-40
3	NUT	2	M3
4	LONG SCREW	2	M3
5	SMALL WASHER	2	
6	SHORT SCREW	2	M3
7	7.1 METAL WASHER	2	M3
	7.2 PLASTIC-1 WASHER	2	ABS
	7.3 PLASTIC-2 WASHER	2	ABS

REV.	DESCRIPTION	DRAWN	CHECKED	APPROVED
A	NEW RELEASE	LJH 08/13/05'	~	LJC 08/13/05'
B	整理图画	YCH 09/13/07'	~	LJC 09/13/07'
C	整理英制短螺丝尺寸	YCH 07/18/08'	~	

NOTES:

1. Hardwares are all Nickel plated.
2. PART NUMBER CODE:

DS1045 - 09 X X X X X

- Washer type
 - 1: Metal
 - 2: Plastic-1(Lock type)
 - 3: Plastic-2(Screw type)
- Bolt type
 - L: Long
 - S: Short
- Packing type
 - 1: Mix packing
 - 2: Separation packing
- Cover Material
 - P: Plastic(ABS)
- Cover Color
 - A: Gray
 - B: Black
 - V: Ivory
- Position
 - 09: 9pin

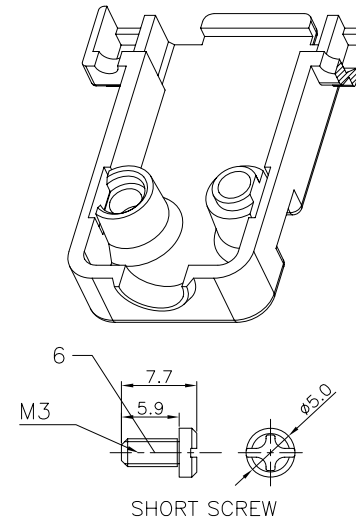

SHORT SCREW

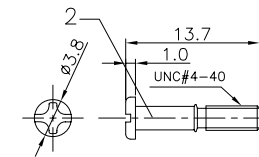

Short BOLT

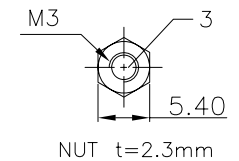

NUT t=2.3mm

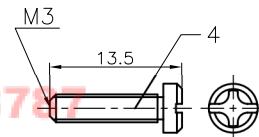

LONG SCREW

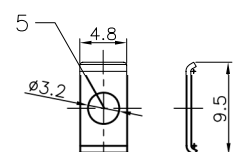

SMALL WASHER

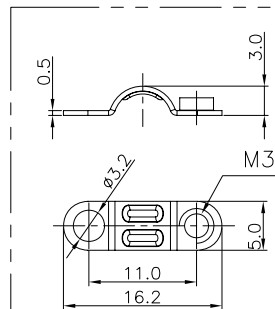
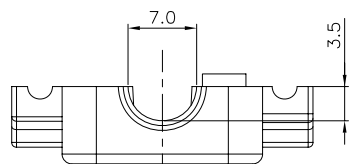
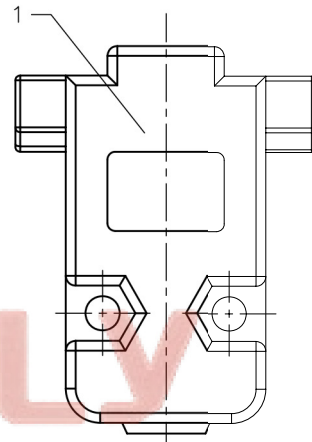
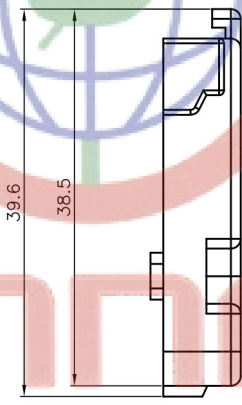
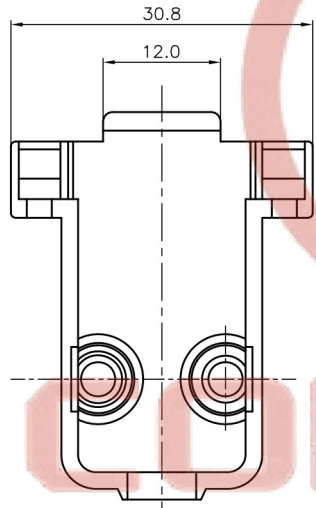
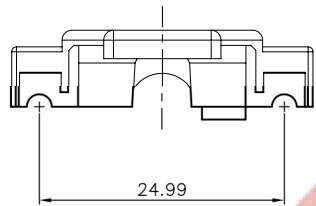

Metal

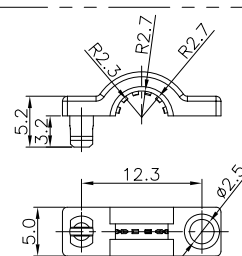

Plastic-1

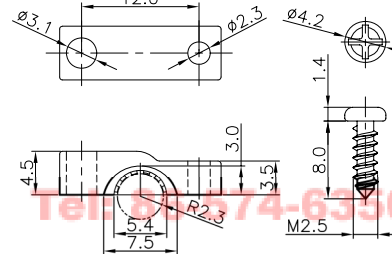

Plastic-2

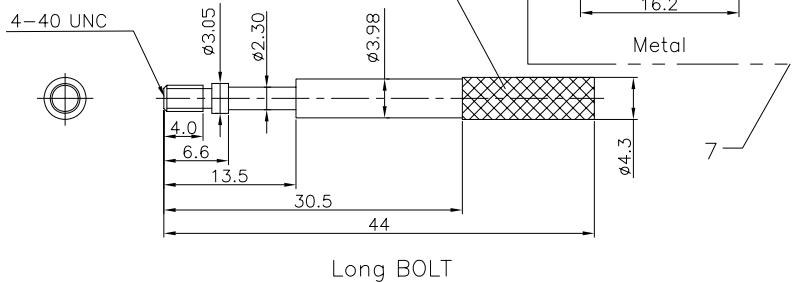

Long BOLT

GENERAL TOLERANCE	
X.	±0.60
.X	±0.38
.XX	±0.25

ANGLE TOLERANCE	
X.	±5°
.X	±3°
.XX	±2°

PROJECTION	TITLE
UNITS	mm
SHEET SIZE	A4

TITLE	
D-SUB	9pin Hood
SERIES	DS1045 SERIES

DRAWING TYPE	CUSTOMER
SCALE	1:1
DRAWING NO.	C-DS1045-09XXXXX-C

晨翔电子有限公司
CONNFLY CONNFLY ELECTRONIC CO. LTD